

LiftMaster®

MEDIUM DUTY DOOR OPERATOR

MODELS MT5011U & BMT5011U

INSTALLATION MANUAL

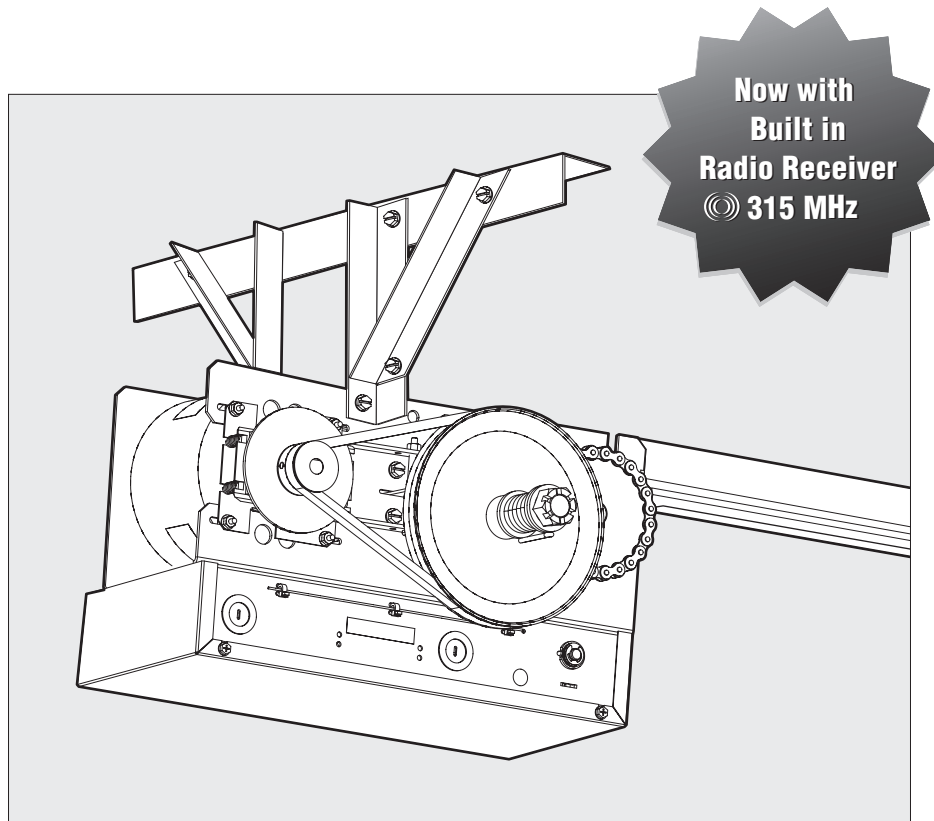

Your model may look different than the model illustrated in this manual.

2 YEAR WARRANTY

Serial # _____
(located on electrical box cover)

Installation Date _____

**THIS PRODUCT IS TO BE
INSTALLED AND SERVICED BY A
TRAINED DOOR SYSTEMS
TECHNICIAN ONLY.**

Visit LiftMaster.com to locate a professional
installing dealer in your area.

OPERATOR RATING: 12 cycles per hour,
50 cycles per day; maximum

NOT FOR RESIDENTIAL USE



TABLE OF CONTENTS

SAFETY INFORMATION	2-3	LOGIC BOARD LAYOUT	19
APPLICATION	3	BASIC PROGRAMMING	20-23
OPERATOR SPECIFICATIONS	4	Determine the Wiring Type	20-21
CARTON INVENTORY	5	Remote Controls.	21-22
PREPARATION	5	Timer-to-Close (TTC)	22-23
ASSEMBLY	6-8	TESTING	23
TYPICAL INSTALLATION	9-14	EMERGENCY DISCONNECT	24
Install the Header Bracket	9	TROUBLESHOOTING	25-26
Install the Operator	10-11	DIAGRAM	26
Power Ground Wiring Connections	11-12	ACCESSORIES	27
Install 3-Button Control Station	12-13	CONTROL CONNECTION DIAGRAM	BACK COVER
Setup Radio Antenna	13-14		
ADJUSTMENT	15		
Adjust the Limits.	15		
Adjust the Clutch.	15		
ENTRAPMENT PROTECTION	16-19		
LiftMaster Monitored Entrapment Protection (LMEP)	16		
Install the Photoelectric Sensors.	17		
Mount the Photoelectric Sensors	18		
Entrapment Protection Wiring Options	18-19		

SAFETY INFORMATION

 **WARNING**

Mechanical

 **WARNING**

Electrical

When you see these Safety Symbols and Signal Words on the following pages, they will alert you to the possibility of **serious injury** or **death** if you do not comply with the warnings that accompany them. The hazard may come from something mechanical or from electric shock. Read the warnings carefully.

 **WARNING:** This product can expose you to chemicals including lead, which are known to the State of California to cause cancer or birth defects or other reproductive harm. For more information go to www.P65Warnings.ca.gov.

 **CAUTION**

When you see this Signal Word on the following pages, it will alert you to the possibility of damage to your door and/or the door operator if you do not comply with the cautionary statements that accompany it. Read them carefully.

IMPORTANT NOTES:

- BEFORE attempting to install, operate or maintain the operator, you must read and fully understand this manual and follow all safety instructions.
- DO NOT attempt repair or service of your commercial door and gate operator unless you are an Authorized Service Technician.

SAFETY INFORMATION

IMPORTANT INSTALLATION INSTRUCTIONS

WARNING

To reduce the risk of SEVERE INJURY or DEATH:

1. READ AND FOLLOW ALL INSTALLATION WARNINGS AND INSTRUCTIONS.
2. Install door operator ONLY on properly balanced and lubricated door. An improperly balanced door may not reverse when required and could result in SEVERE INJURY or DEATH.
3. ALL repairs to cables, spring assemblies and other hardware MUST be made by a trained door systems technician BEFORE installing operator.
4. Disable ALL locks and remove ALL ropes connected to door BEFORE installing operator to avoid entanglement.
5. Install door operator 8 feet (2.44 m) or more above floor.
6. NEVER connect door operator to power source until instructed to do so.
7. NEVER wear watches, rings or loose clothing while installing or servicing operator. They could be caught in door or operator mechanisms.
8. Install control station:
 - within sight of the door.
 - out of reach of children at minimum height of 5 feet (1.5 m) above floors, landings, steps, or any other adjacent walking surface.
 - away from ALL moving parts of the door.
9. Install the control station far enough from the door to prevent the user from coming in contact with the door while operating the controls.
10. Install the entrapment warning placard on wall next to the control station in a prominent location that is visible from the door.
11. Place manual release/safety reverse test label in plain view on inside of door.
12. Upon completion of installation, test entrapment protection device.
13. This door operator is NOT intended to replace door locks. With enough force, a door without a door lock can be opened. LiftMaster ALWAYS recommends the use of door locks to properly secure a door.
14. **SAVE THESE INSTRUCTIONS.**

APPLICATION

This operator includes a number of features that will provide years of reliable and safe operation.

FEATURES:

- **Supports both monitored and non-monitored entrapment protection devices:** Entrapment protection devices detect obstructions in the door's path and automatically reverse a closing door.
- **Radio receiver:** A factory installed radio receiver allows remote controls, keyless entries and other remote command devices to be programmed to the operator.
- **Timer-to-Close:** The Timer-to-Close feature allows the door to automatically close after a preset time (only available with B2 wiring and a monitored entrapment protection device).
- **Wiring Types:** The functionality of the operator is based on the wiring type. The operator is shipped from the factory in standard C2 wiring type (factory default). Some wiring types will require an optional monitored entrapment protection device. Refer to Basic Programming Section for descriptions of wiring types, requirements and programming.

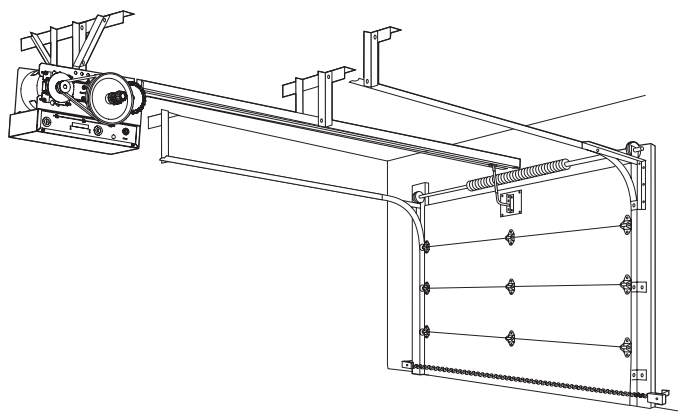

MAXIMUM DOOR AREA AND MAXIMUM DOOR HEIGHT 14 FEET

SECTIONAL DOOR	---	24 ga., 22 ga. Steel	20 ga. Steel	16 ga. Steel	---
	Fiberglass	Aluminum Doors	Wood Doors	---	---
	---	---	24 ga. Steel Insulated	20 ga. Steel Insulated	16 ga. Steel Insulated
SQ. FT	310	260	225	150	100

NOTE: Actual track length will exceed door height by 2 feet.

CARTON INVENTORY

Before beginning your installation check that all components were provided.

NOTE: The tracks are shipped separately. Actual track length will exceed door height by 2 feet. **EXAMPLE:** The track for 12 foot (3.7 m) door will be 14 feet (4.3 m).

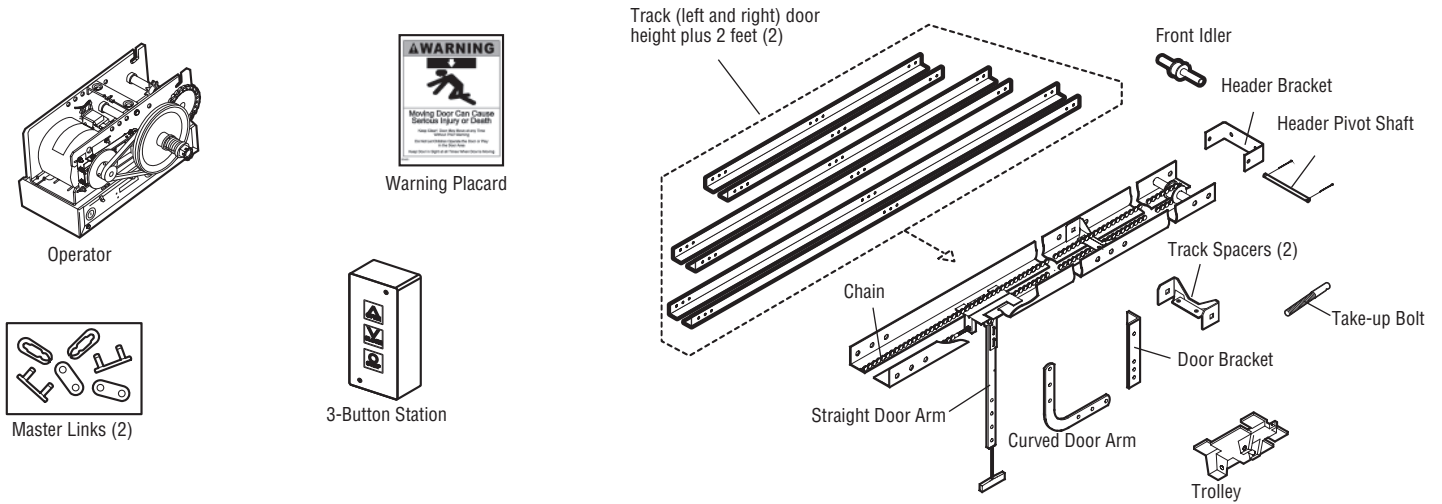

NOT SHOWN

Installation Manual

Quickstart Guide

User's Guide

Entrapment Warning Placard

Installation Hardware Bag, Complete with: Bolts 3/8"-16 x 3/4" (10), Flanged Hex Nuts 3/8"-16 (14), Bolt 3/8"-16 x 1 (3), Lock Washers 3/8" (3), Cotter Pins (2) and Carriage Bolts (2)

NOTE: Depending on door height, the quantity of track spacers and hardware may vary.

PREPARATION

PREPARING YOUR DOOR

The manufacturer recommends 3 feet (0.9 cm) of clearance around the operator for serviceability. Before you begin:

- Disable locks.
- Remove any ropes connected to door.
- Before the operator is installed, be sure the door has been properly aligned and is working smoothly. Although each installation will vary due to particular building characteristics, refer to the following general procedures to install the operator.

ASSEMBLY

- 1** Install track spacers. Position the track spacers evenly over the length of the track using the pre-punched holes.

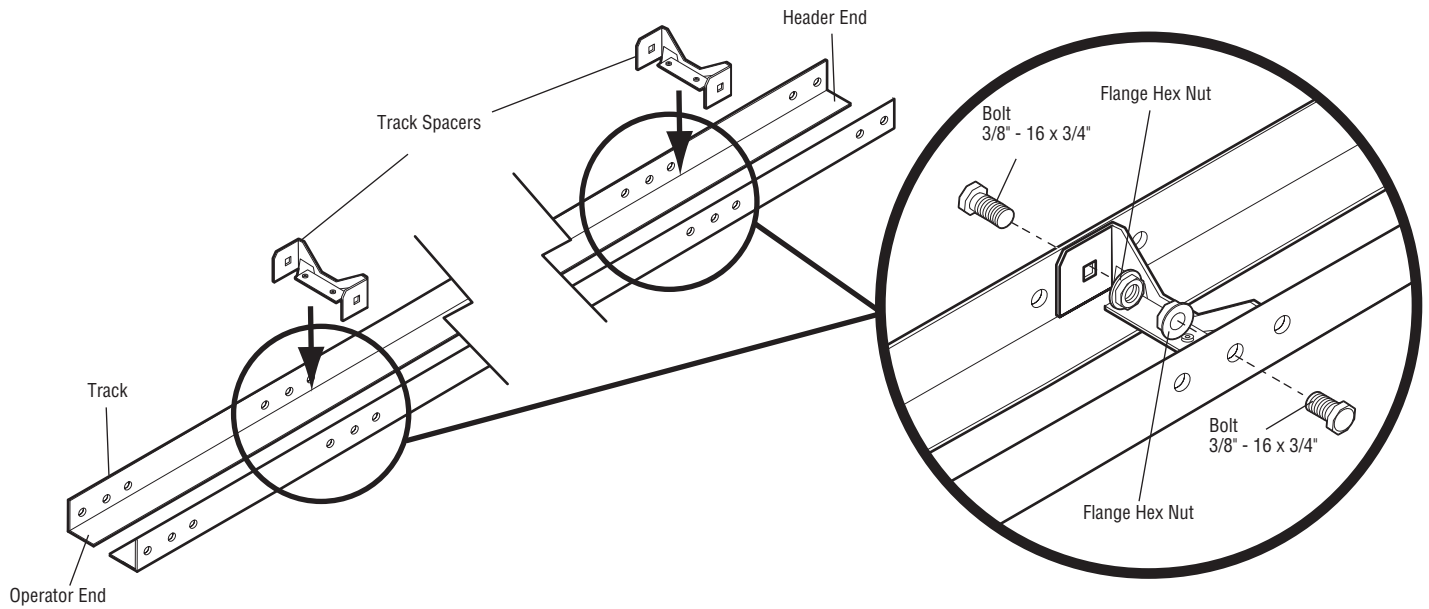

- 2** Install front idler.

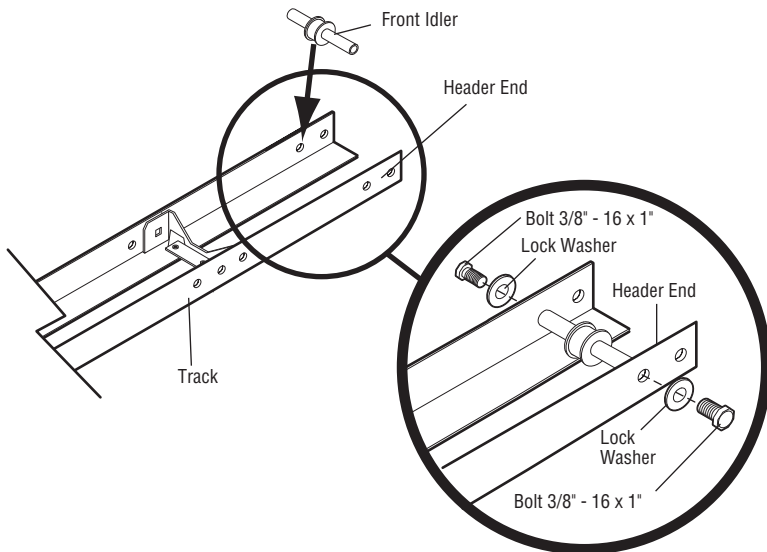

- 3** Assemble trolley.

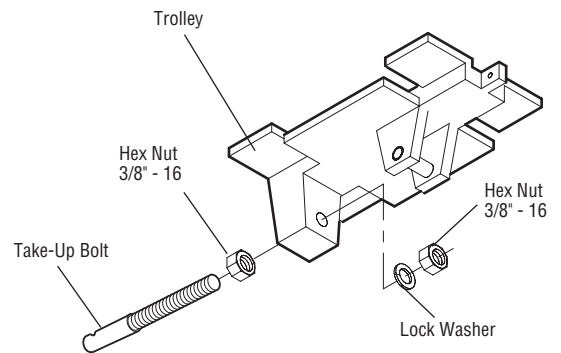

ASSEMBLY

4 Slide trolley onto the track.

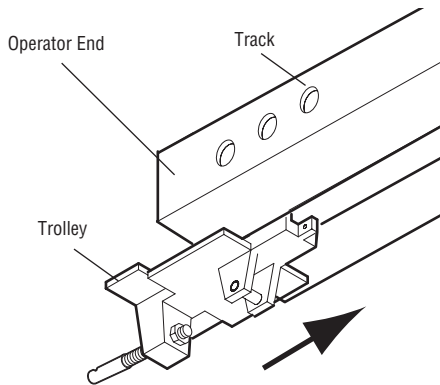

5 Attach track to operator.

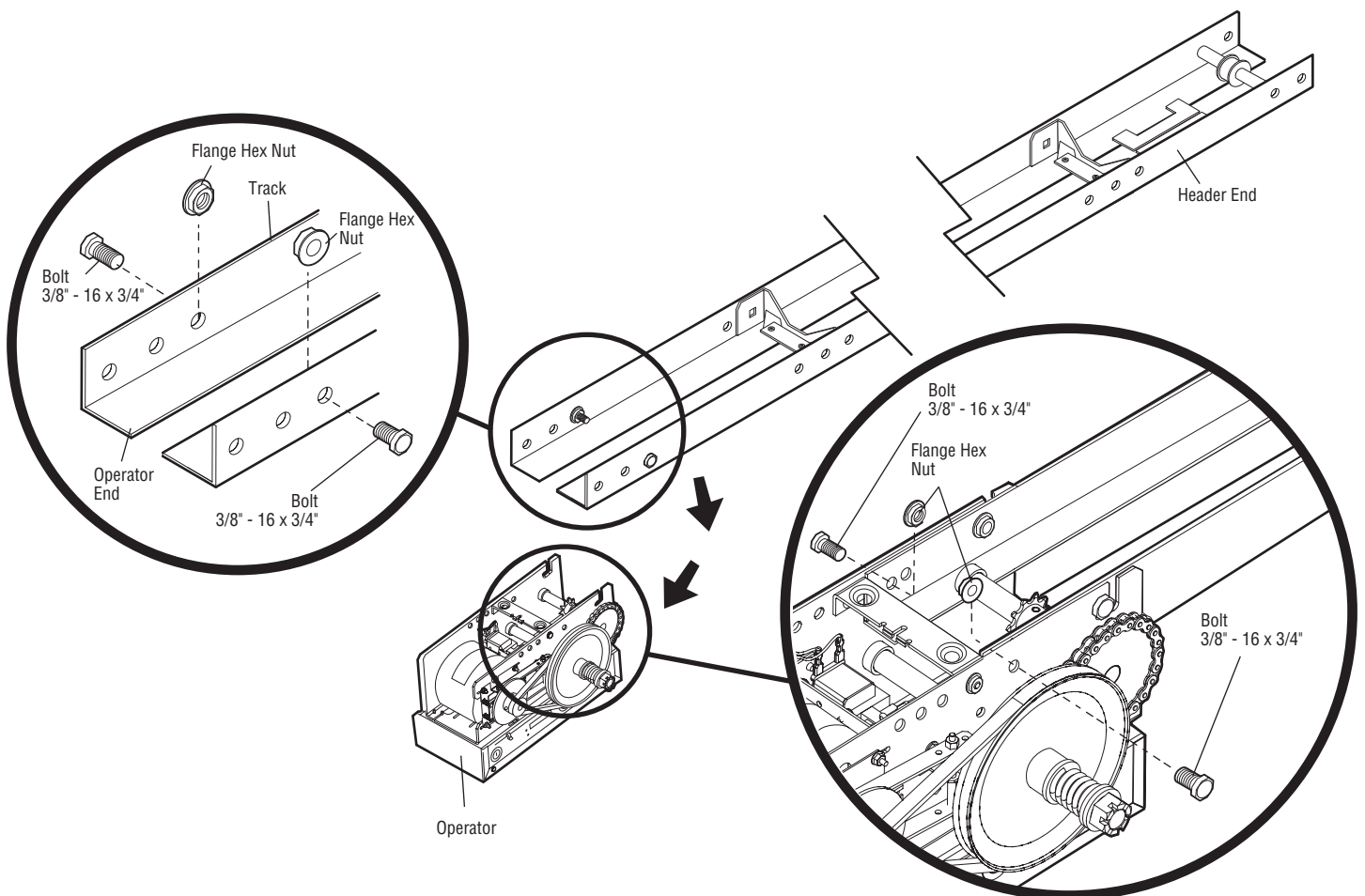

ASSEMBLY

6 Attach chain to front of trolley.

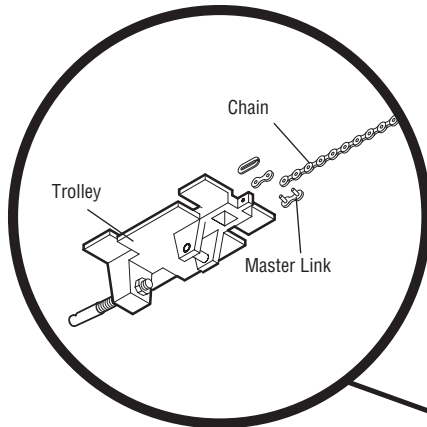

7 Wrap chain around front idler in the direction shown.

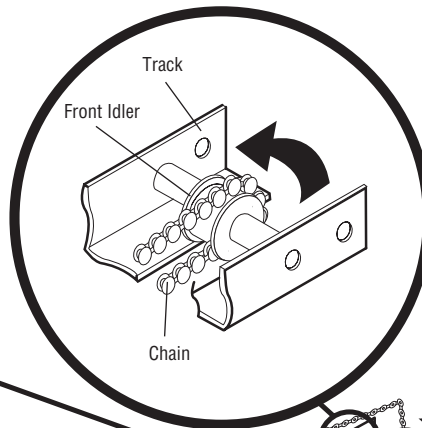

8 Slide trolley 2 inches away from front idler.

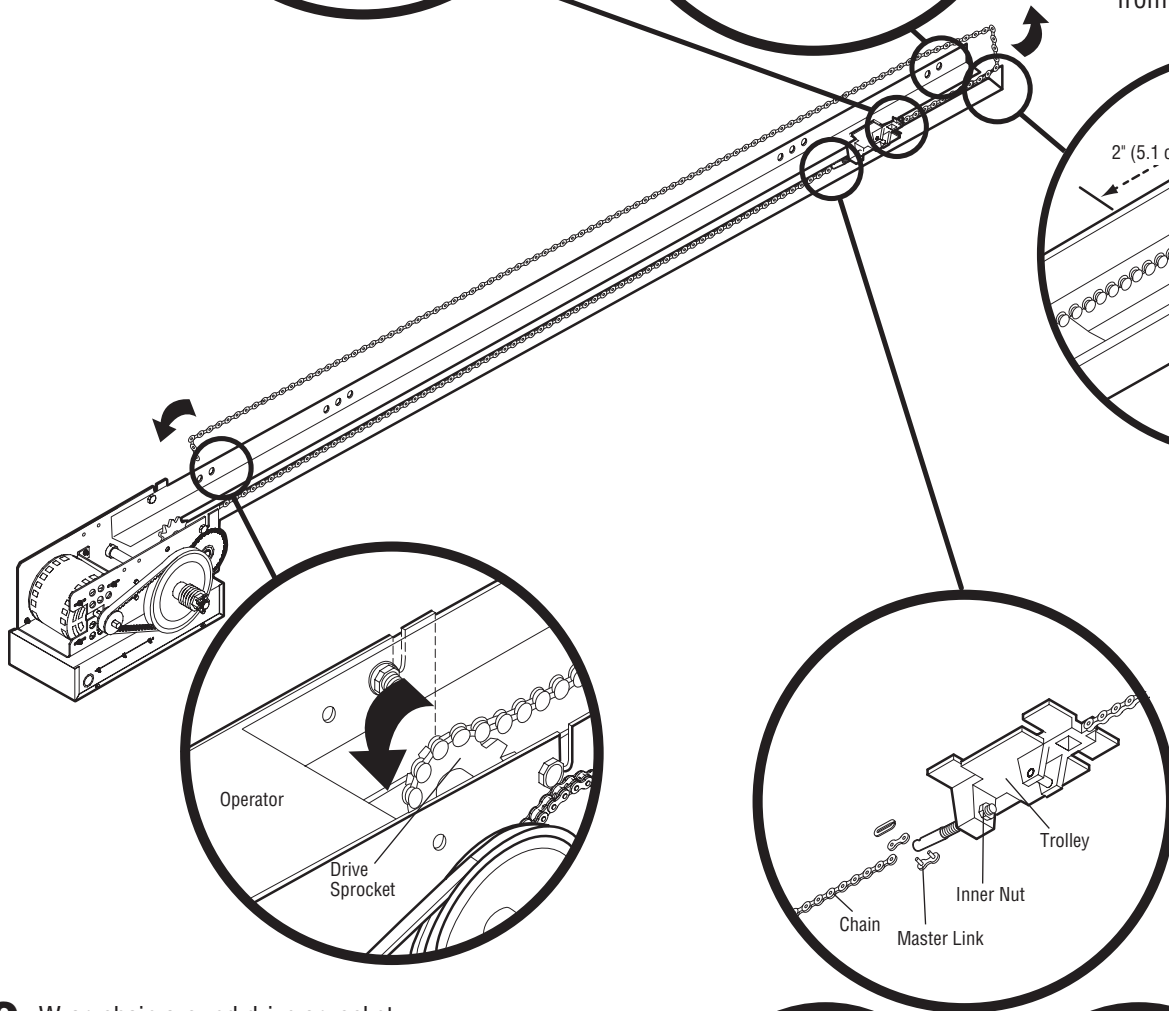
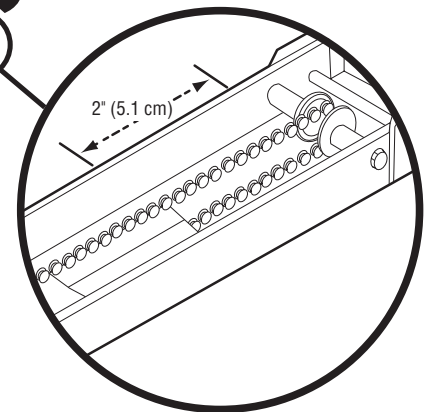

9 Wrap chain around drive sprocket.

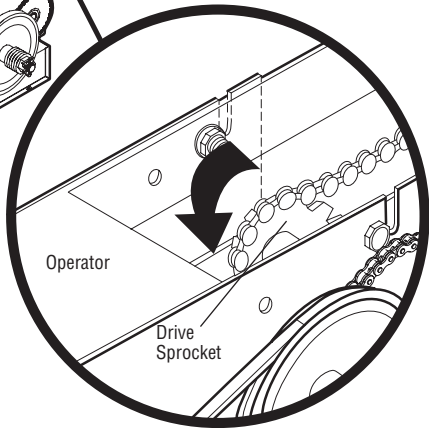

10 Attach chain to back of trolley. Adjust the chain by tightening the inner nut.

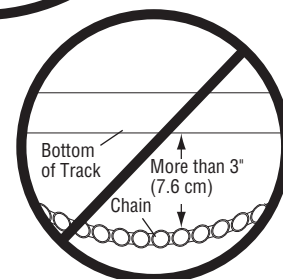
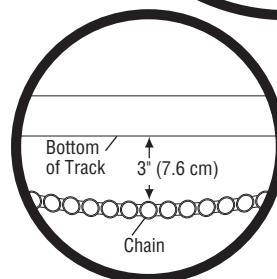
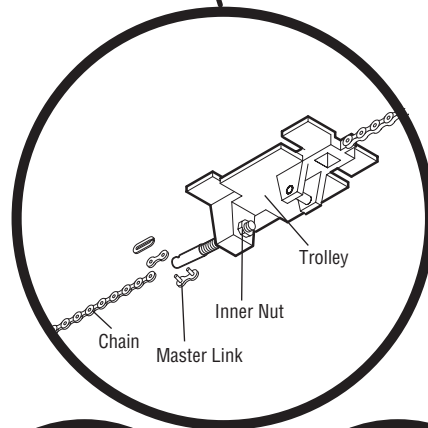

TYPICAL INSTALLATION

INSTALL THE HEADER BRACKET

⚠ WARNING

To prevent possible SERIOUS INJURY or DEATH:

- Header bracket **MUST** be RIGIDLY fastened to structural support on header wall or ceiling, otherwise door might not reverse when required. **DO NOT** install header bracket over drywall.
- Concrete anchors **MUST** be used if mounting header bracket or 2x4 into masonry.
- NEVER try to loosen, move or adjust door, springs, cables, pulleys, brackets, or their hardware, ALL of which are under EXTREME tension.
- ALWAYS call a trained door systems technician if door binds, sticks, or is out of balance.

The trolley operator is generally mounted over the center of the door. However, off center mounting may be required due to interfering structures or location of door stile / top section support. Typically, the operator may be mounted up to 24 inches (61 cm) off center on torsion spring doors. Extension springs require center mounting.

- 1** Mark the center of the door. Extend the line on to the header wall and the ceiling.

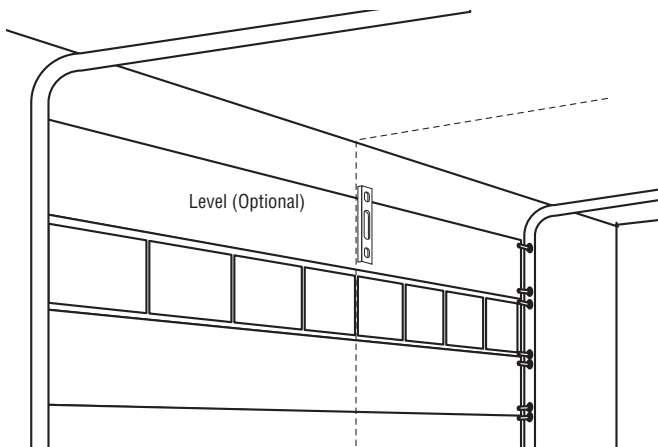

- 2** Determine and mark the highest point of door travel.

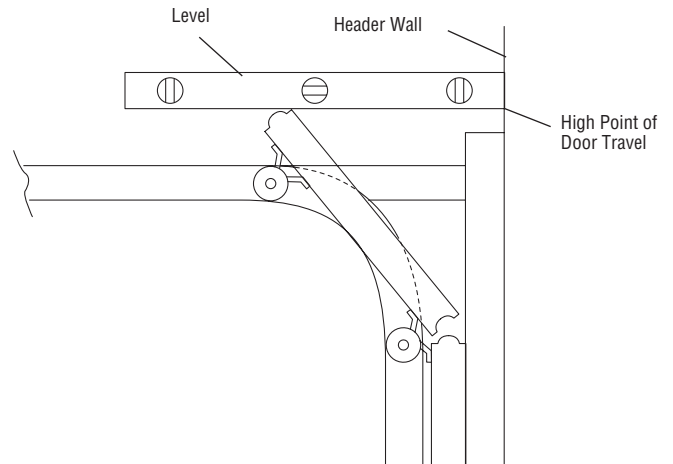

- 3** Center header bracket over vertical center line and horizontal line created in step 2. Drill appropriate pilot holes to accommodate mounting hardware.

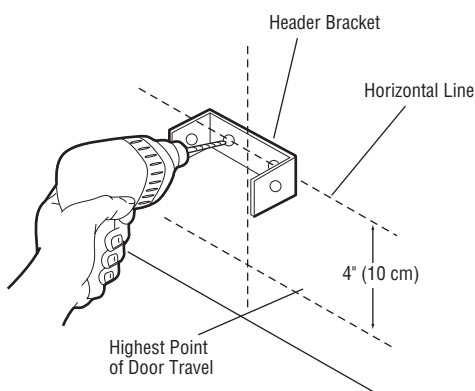

- 4** Secure the header bracket to the header using the appropriate method.

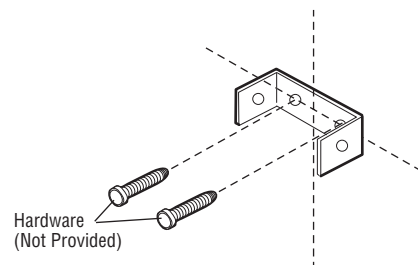

TYPICAL INSTALLATION

INSTALL THE OPERATOR

⚠ CAUTION

To avoid possible SERIOUS INJURY from a falling operator:

- Fasten the operator SECURELY to structural supports of the building.
- Concrete anchors MUST be used if installing ANY brackets into masonry.

1 Swing the operator to a horizontal position and temporarily secure with rope, chain or support from floor. Make sure that the operator is aligned with the header bracket.

2 Align holes in track with holes in header bracket and secure with cotter pin.

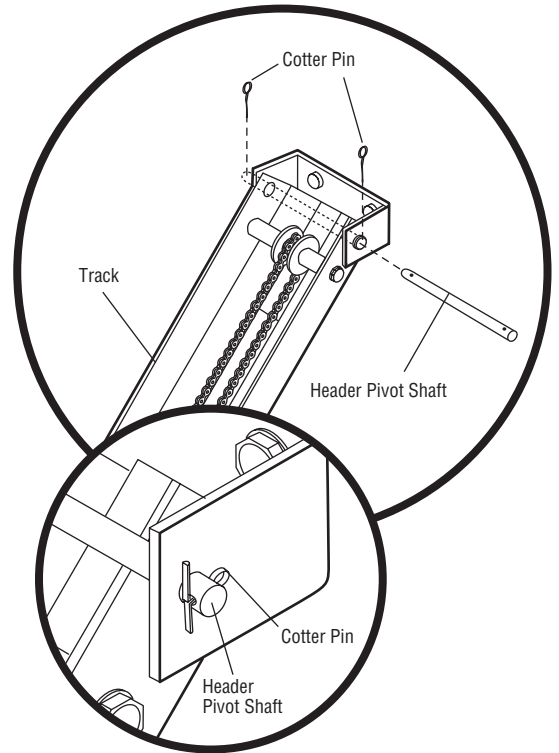
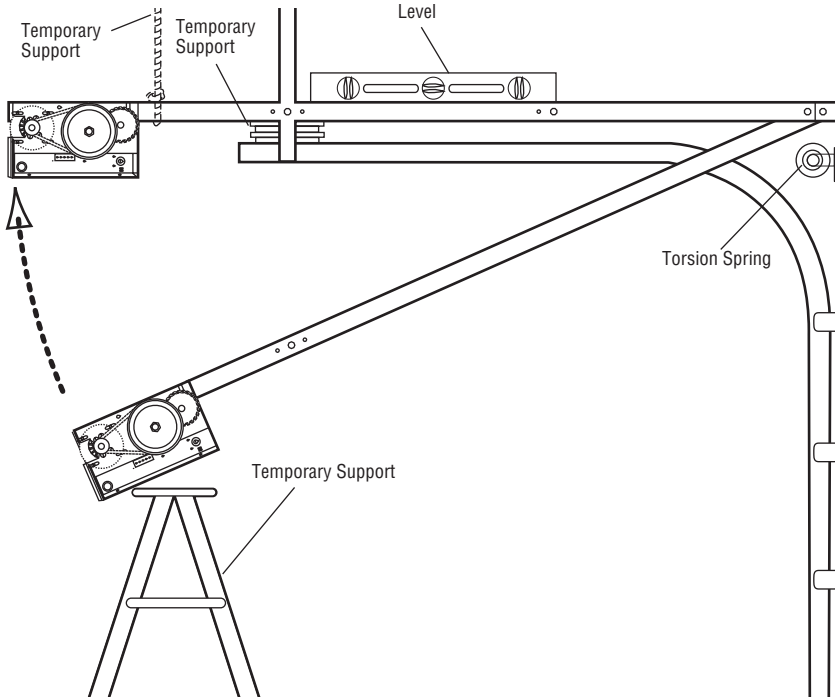

3 Secure the operator using appropriate fasteners and locking hardware that will support the weight of the operator.

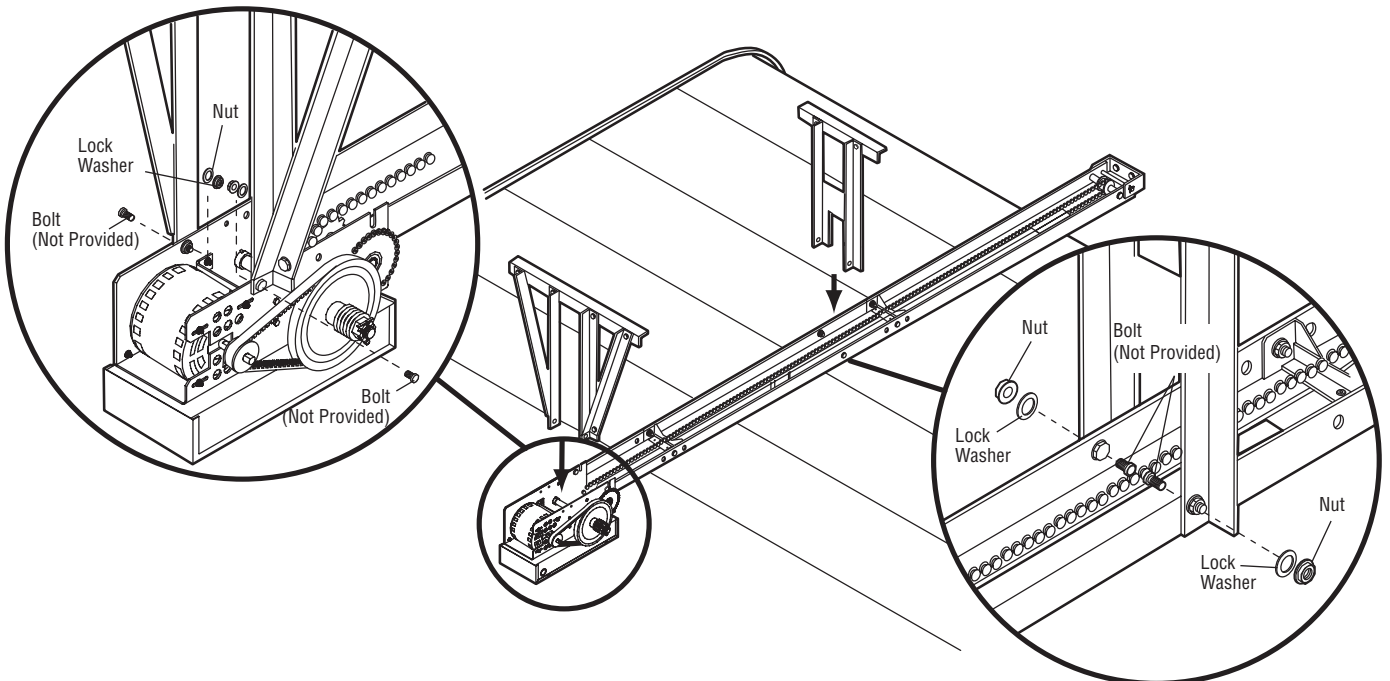

TYPICAL INSTALLATION

INSTALL THE OPERATOR

4 Attach the door arms to the trolley and door bracket. Make sure the open side of the notch on the door arm faces the door.

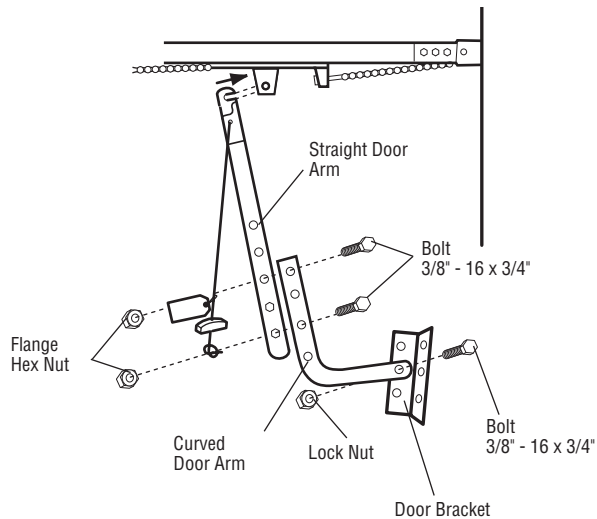

5 Use appropriate hardware to secure door bracket to door (not provided). **NOTE:** When properly installed and adjusted the door arm should be leaning back toward the operator slightly. Refer to door manufacturer's instructions for recommended installation guidelines.

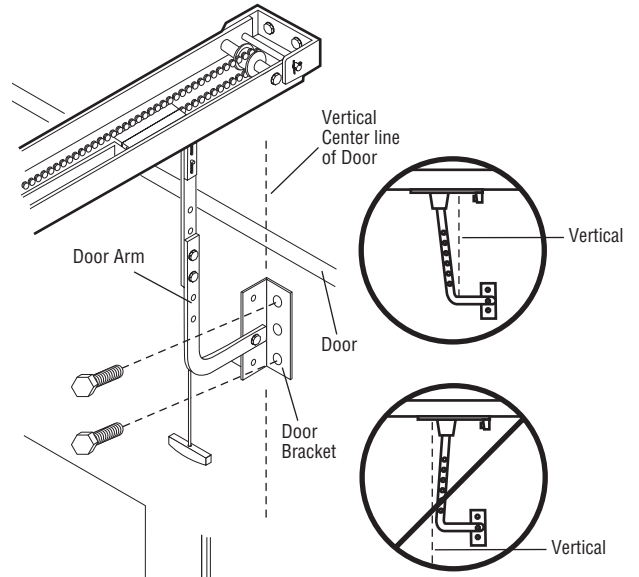

POWER AND GROUND WIRING CONNECTIONS

⚠️ ⚡ WARNING

To reduce the risk of SEVERE INJURY or DEATH:

- ANY maintenance to the operator or in the area near the operator MUST NOT be performed until disconnecting the electrical power and locking-out the power. Upon completion of maintenance the area MUST be cleared and secured, at that time the unit may be returned to service.
- Disconnect power at the fuse box BEFORE proceeding. Operator MUST be properly grounded and connected in accordance with national and local electrical codes. The operator should be on a separate fused line of adequate capacity.
- ALL electrical connections MUST be made by a qualified individual.
- DO NOT install ANY wiring or attempt to run the operator without consulting the wiring diagram.
- ALL power wiring should be on a dedicated circuit and well protected. The location of the power disconnect should be visible and clearly labeled.
- ALL power and control wiring MUST be run in separate conduit.

NOTE: Power and control wiring must be run in separate conduit in accordance with national and local electrical codes. Must use 14 AWG or heavier wire for power wiring. Use conduit knockouts for wiring as indicated on the electrical box labels.

IMPORTANT NOTE: Operator must be properly grounded. Failure to properly ground the operator could result in electric shock and serious injury.

DO NOT turn power on until you have finished making ALL power and control wiring connections.

POWER WIRING CHART

DISTANCE	GAUGE
50 feet	14 AWG
100 feet	12 AWG
200 feet	8 AWG*
350 feet	6 AWG*
500 feet	4 AWG*
1000 feet	2 AWG*

* Maximum wire gauge that can be connected to the operator's terminal is 12 AWG. When a larger wire gauge is required, the wire must be gauged down to 12 AWG. USE COPPER WIRE ONLY.

TYPICAL INSTALLATION

POWER AND GROUND WIRING CONNECTIONS

1 Remove cover.

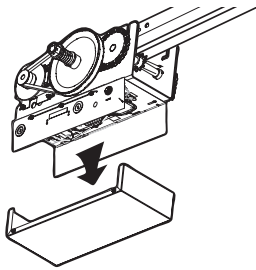

2 Run power wires to electrical box according to national and local electrical codes.

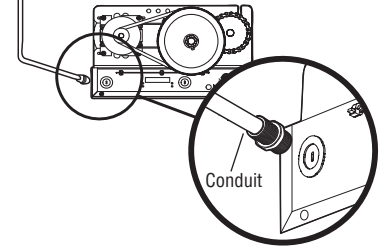

3 Attach power and ground wires to high voltage terminal strip.

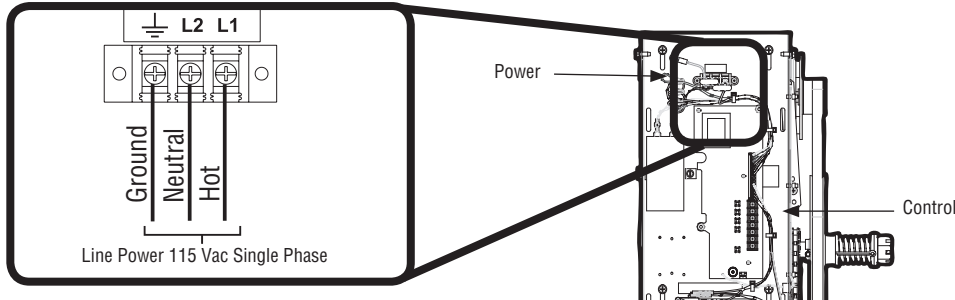

INSTALL 3-BUTTON CONTROL STATION

⚠️ ⚡ WARNING

To prevent possible SERIOUS INJURY or DEATH from electrocution:

- Be sure power is not connected BEFORE installing door control.

To prevent possible SERIOUS INJURY or DEATH from a closing door:

- Install door control within sight of door, out of reach of children at a minimum height of 5 feet (1.5 m) above floors, landings, steps, or any other adjacent walking surface, and away from ALL moving parts of door.
- Install the control station far enough from the door to prevent the user from coming in contact with the door while operating

the controls.

- Install the entrapment warning placard on wall next to the control station in a prominent location that is visible from the door.
- NEVER permit children to operate or play with door control push buttons or remote controls.
- Activate door ONLY when it can be seen clearly, is properly adjusted and there are no obstructions to door travel.
- ALWAYS keep door in sight until completely closed. NEVER permit anyone to cross path of closing door.

1 Remove the control station cover.

2 Fasten the control station to the wall at least 5 feet (1.5 m) above floors, landings, steps, or any other adjacent walking surface. **The installation surface must be smooth and flat.**

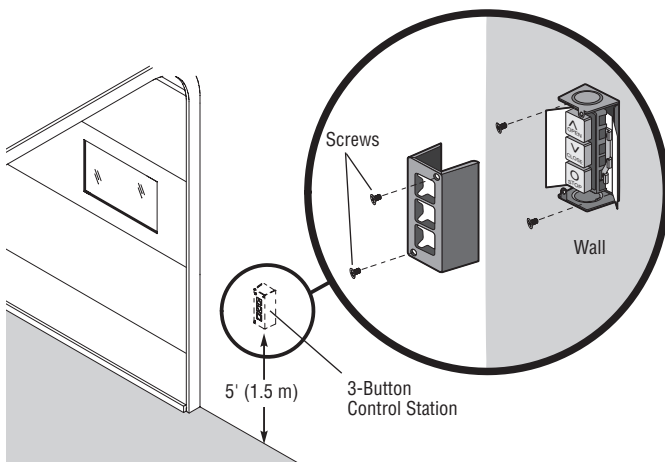

3 Select appropriate knockout and run the wires to the operator.

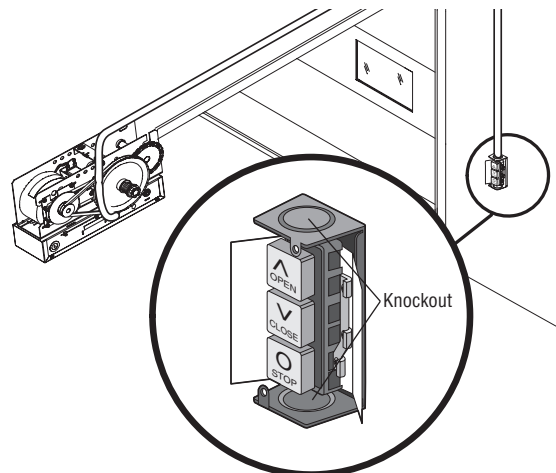

TYPICAL INSTALLATION

INSTALL 3-BUTTON CONTROL STATION

- 4 Connect wires to the control station and replace the control station cover.

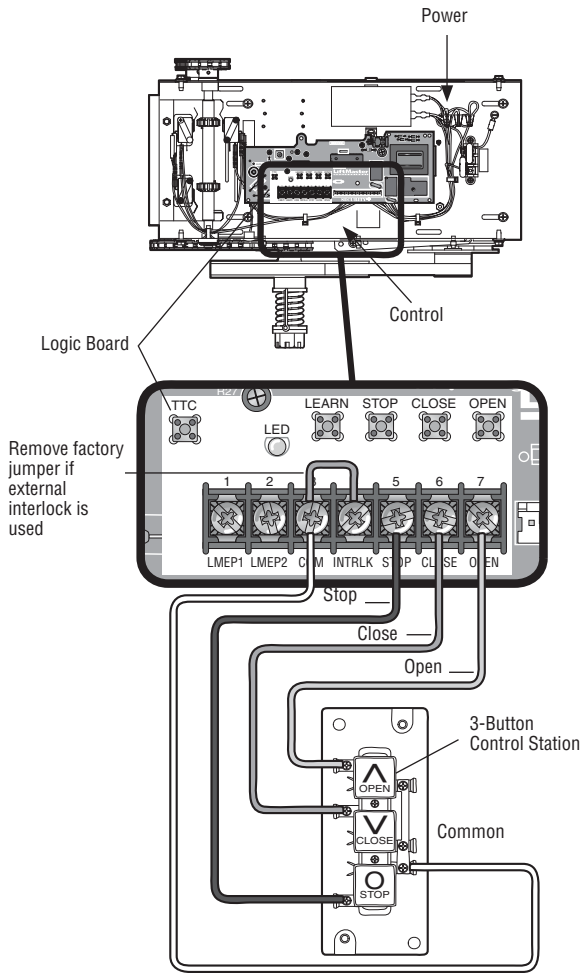

- 5 Fasten the entrapment warning placard next to the control station.

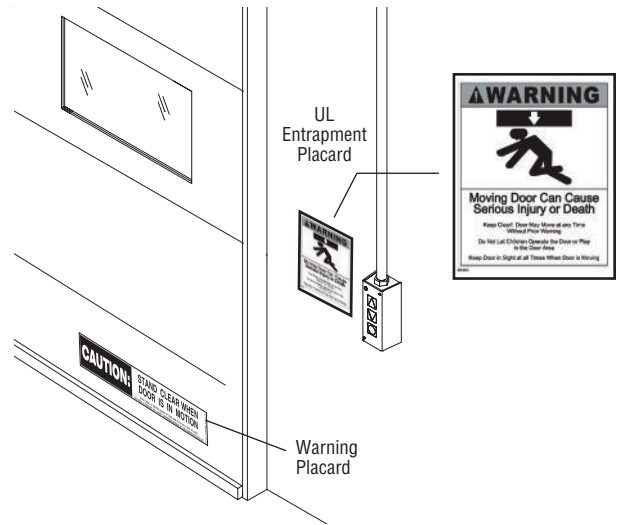

SETUP RADIO ANTENNA

OPTION A

- 1 Locate the wire antenna on the outside of the electrical box. Cut the wire tie closest to the edge of the electrical box.

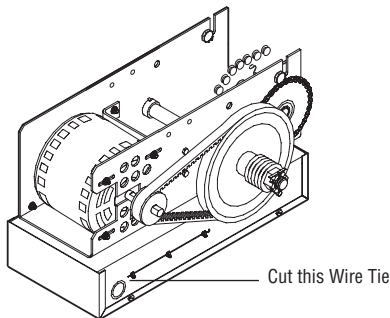

- 2 Press the plastic standoff into the hole in the side of the electrical box.

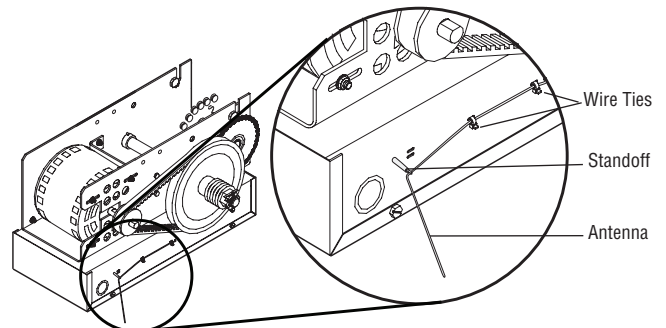

TYPICAL INSTALLATION

SETUP RADIO ANTENNA

OPTION B

- 1 Locate the wire antenna on the outside of the electrical box. Cut wire ties and discard standoff.
- 2 Attach the antenna to the electrical box using the wire tie holes. Bend antenna across the front of the electrical box, ensuring that the antenna is 4 inches (10 cm) away from the front of the electrical box.

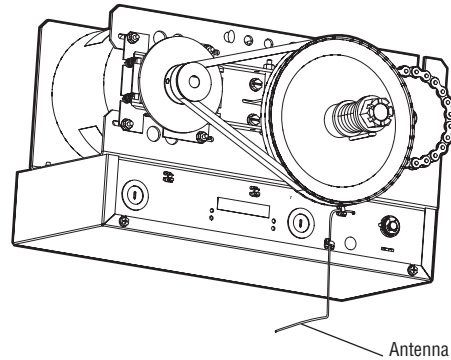
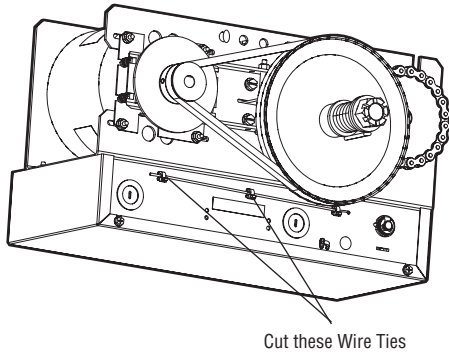

NOTICE: To comply with FCC and or Industry Canada (IC) rules, adjustment or modifications of this receiver and/or transmitter are prohibited, except for changing the code setting or replacing the battery. THERE ARE NO OTHER USER SERVICEABLE PARTS.
Tested to Comply with FCC Standards FOR HOME OR OFFICE USE. Operation is subject to the following two conditions: (1) this device may not cause harmful interference, and (2) this device must accept any interference received, including interference that may cause undesired operation.

IMPORTANT SAFETY INSTRUCTIONS

WARNING

To reduce the risk of SEVERE INJURY or DEATH:

1. READ AND FOLLOW ALL WARNINGS AND INSTRUCTIONS.
2. ALWAYS keep remote controls out of reach of children. NEVER permit children to operate or play with door control push buttons or remote controls.
3. ONLY activate door when it can be seen clearly, it is properly adjusted and there are no obstructions to door travel.
4. ALWAYS keep door in sight until completely closed. NO ONE SHOULD CROSS THE PATH OF THE MOVING DOOR.
5. NO ONE SHOULD GO UNDER A STOPPED, PARTIALLY OPENED DOOR.
6. If possible, use manual release handle to disengage door ONLY when door is CLOSED. Weak or broken springs or unbalanced door could result in an open door falling rapidly and/or unexpectedly.
7. NEVER use manual release handle unless doorway is clear of persons and obstructions.
8. After ANY adjustments are made, the entrapment protection device MUST be tested.
9. Entrapment Protection device MUST be tested every month.
10. ALWAYS KEEP DOOR PROPERLY BALANCED. An improperly balanced door may not reverse when required and could result in SEVERE INJURY or DEATH.
11. ALL repairs to cables, spring assemblies and other hardware, ALL of which are under EXTREME tension, MUST be made by a trained door systems technician.
12. ALWAYS disconnect electric power to door operator BEFORE making ANY repairs or removing covers.
13. **SAVE THESE INSTRUCTIONS.**

ADJUSTMENT

ADJUST THE LIMITS

WARNING

To avoid **SERIOUS** personal **INJURY** or **DEATH** from electrocution:

- Disconnect electric power **BEFORE** performing **ANY** adjustments or maintenance.

1 Depress retaining plate.

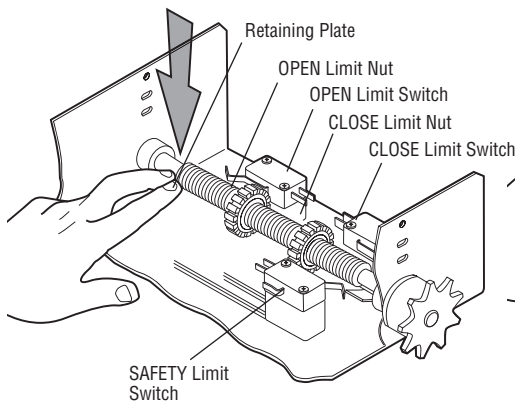

2 Adjust OPEN limit.

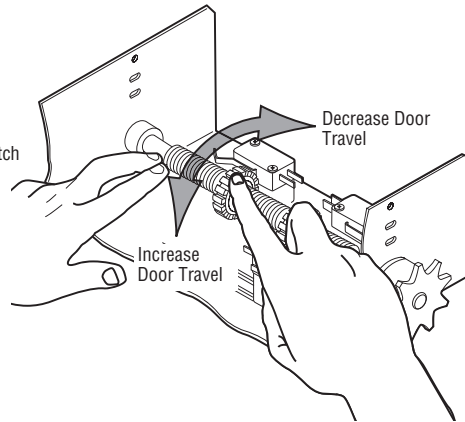

3 Adjust CLOSE limit.

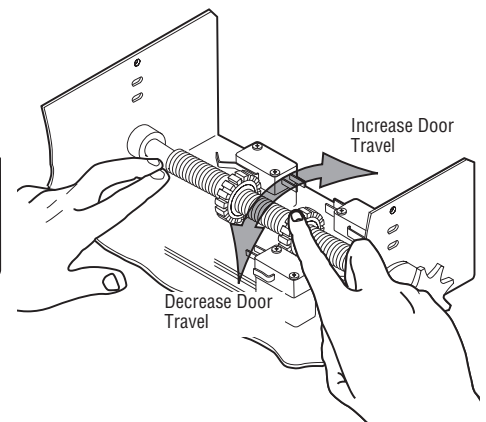

NOTE: When retaining plate is released, verify that the retaining plate is fully seated with the notches of the limit nut.

ADJUST THE CLUTCH

- 1** Apply power to operator. Remove tape holding cotter pin to spring.
- 2** Turn clutch nut to release tension.
- 3** Re-tighten nut until there is just enough tension to permit smooth operation.
- 4** Replace cotter pin. Bend ends of cotter pin to secure clutch nut.

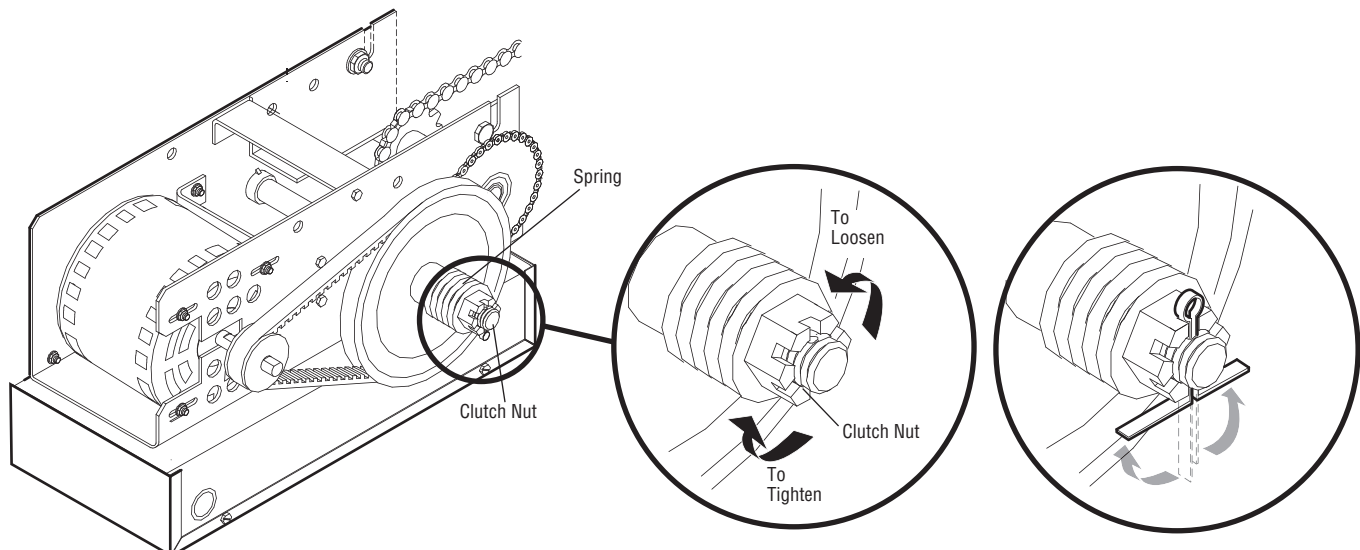

ENTRAPMENT PROTECTION

LIFTMASTER MONITORED ENTRAPMENT PROTECTION (LMEP)

IMPORTANT INFORMATION ABOUT THE LIFTMASTER MONITORED ENTRAPMENT PROTECTION DEVICES

A LiftMaster Monitored Entrapment Protection (LMEP) device is required for most wiring types. If a LiftMaster Monitored Entrapment Protection device is not installed, constant pressure to close will be required from the control station.

When properly connected and aligned, the photoelectric sensors will detect an obstruction in the path of its invisible light beam. If an obstruction breaks the light beam while the door is closing, the door will stop and typically reverse to the full open position.

The photoelectric sensors must be installed facing each other across the door, no more than 6" (15 cm) above the floor.

Each photoelectric sensor has an LED that will glow steady when the sensor is properly connected and aligned. The LEDs on both photoelectric sensors will flicker rapidly when obstructed or misaligned.

WARNING

To prevent possible **SERIOUS INJURY** or **DEATH** from a closing door:

- Be sure power is not connected to the door operator **BEFORE** installing the photoelectric sensor.
- The door **MUST** be in the fully opened or closed position **BEFORE** installing the LiftMaster Monitored Entrapment Protection device.

To prevent **SERIOUS INJURY**, **DEATH**, **ENTRAPMENT**, or **PROPERTY DAMAGE**:

- Correctly connect and align the photoelectric sensor.
- Install the photoelectric sensor beam **NO HIGHER** than 6" (15 cm) above the floor.
- This is a required safety device for B2, TS, T, and FSTS wiring types and **MUST NOT** be disabled. For D1, C2, and E2 wiring the installation of an entrapment device is recommended.
- LiftMaster Monitored Entrapment Protection devices are for use with LiftMaster Commercial Door Operators **ONLY**. Use with **ANY** other product voids the warranty.
- If an edge sensor is being used on a horizontal slide door, then place one or more edge sensors on both the leading and trailing edge.
- If an edge sensor is being used on a vertically moving door, then place one or more edge sensors on the bottom edge of the door.

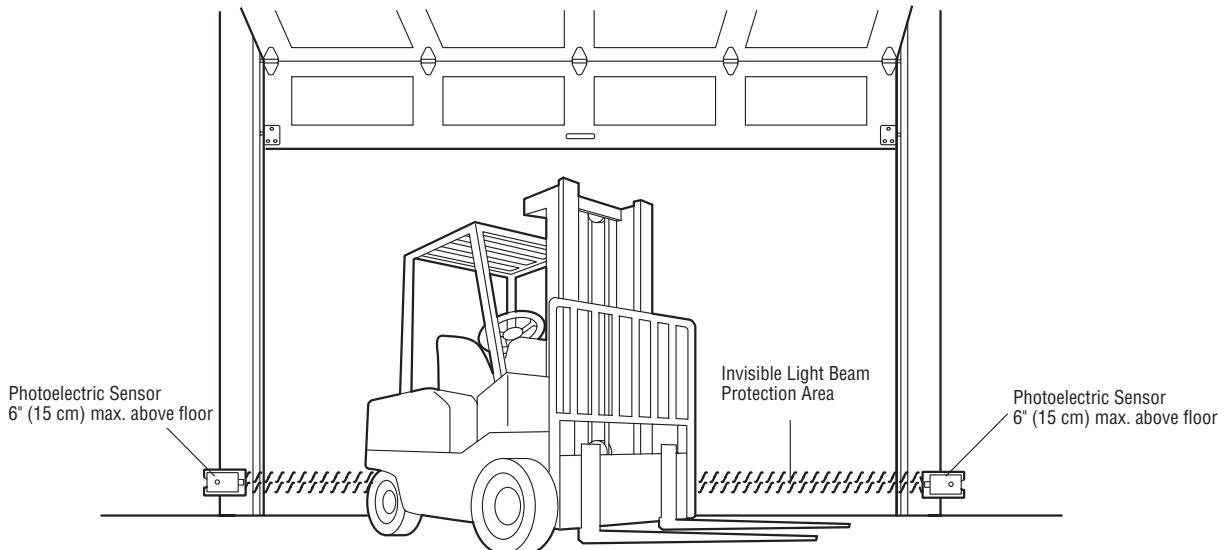

ENTRAPMENT PROTECTION

INSTALL THE PHOTOELECTRIC SENSORS

The following instructions show recommended assembly of the bracket(s) and "C" wrap based on the wall installation of the photoelectric sensors on each side of the door or on the door tracks themselves. There are also alternate mounting methods which may fit your installation requirements better.

Make sure the wraps and brackets are aligned so the photoelectric sensors will face each other across the door.

- 1 Fasten the "C" wraps to the mounting brackets having square holes, using hardware shown.

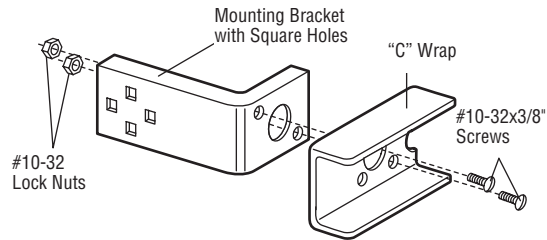

WALL INSTALLATION

- 2 Connect each assembly to a slotted bracket, using the hardware shown. **Note alignment of brackets for left and right sides of the door.**
- 3 Finger tighten the lock nuts.
- 4 Use bracket mounting holes as a template to locate and drill (2) 3/16" diameter pilot holes on both sides of the garage door, 4-6 inches (10-15 cm) above the floor. Do not exceed 6 inches (15 cm).
- 5 Attach bracket assemblies with 1/4"x1-1/2" lag screws.
- 6 Adjust right and left side bracket assemblies to the same distance out from mounting surface. Make sure all door hardware obstructions are cleared. Tighten the nuts securely.

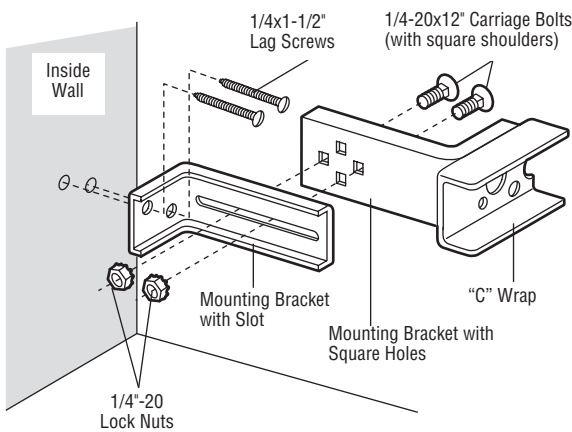

DOOR TRACK INSTALLATION

- 2 Discard slotted bracket. Drill 3/8" holes in each track and fasten securely with hardware.

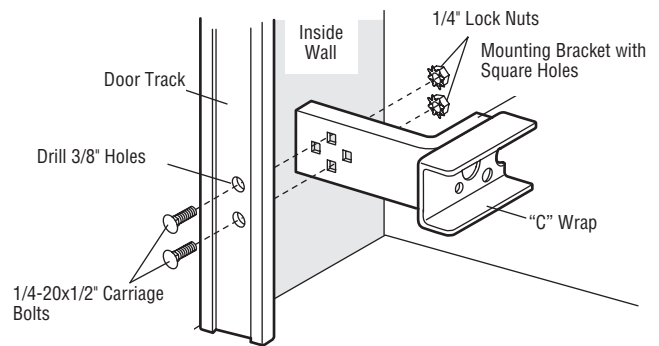

ALTERNATE WALL INSTALLATION

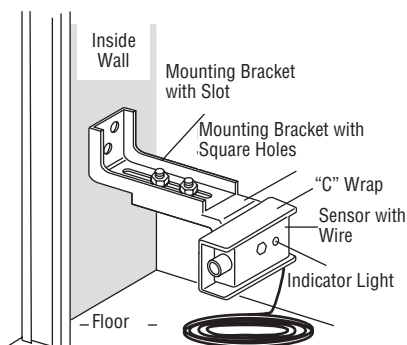

ALTERNATE FLOOR INSTALLATION

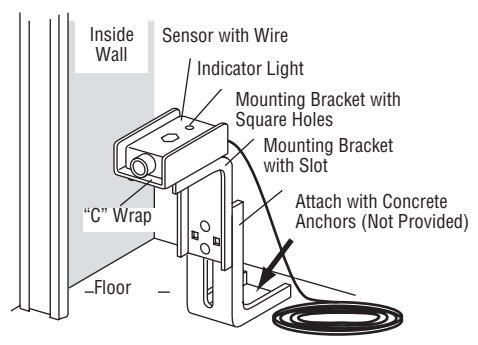

ENTRAPMENT PROTECTION

MOUNT THE PHOTOELECTRIC SENSORS

- 1** Center each sensor in the bracket with the lenses pointing toward each other across the door.
- 2** Attach the sensors to the brackets with the provided hardware. Finger tighten the *receiving sensor* wing nut. Securely tighten the *sending sensor* wing nut.
- 3** Run the wires from both sensors to the operator. Use insulated staples to secure wire to the wall and ceiling.
- 4** Connect the sensor wires to the operator.

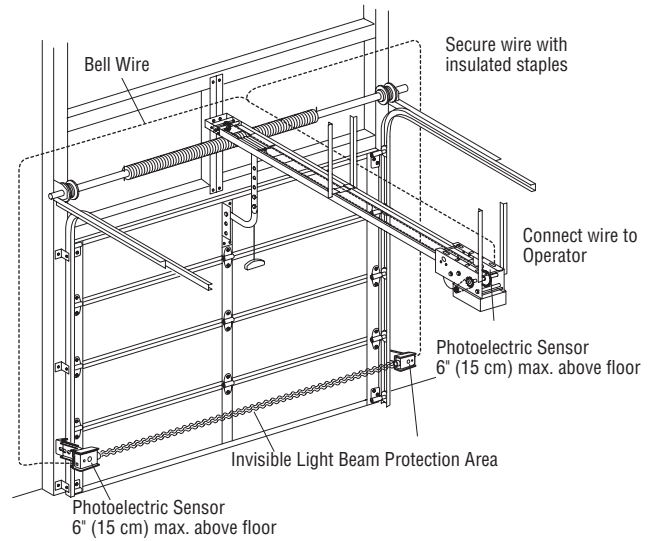
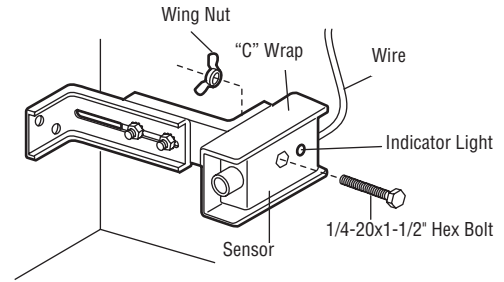

ENTRAPMENT PROTECTION WIRING OPTIONS

PRIMARY INSTALLATION: CPS-U PHOTOELECTRIC SENSORS

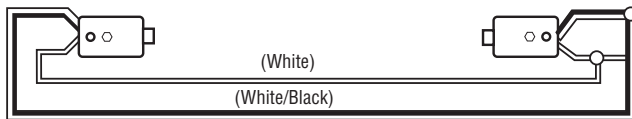

NOTE: When installing model CPS-UN4, connect the brown wire to terminal 1 and the blue wire to terminal 2.

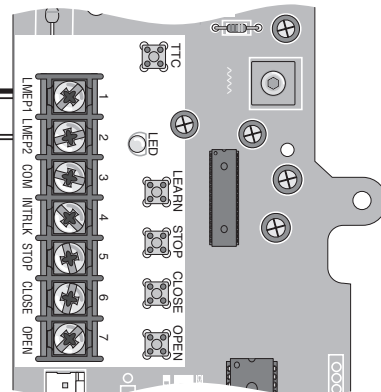

ENTRAPMENT PROTECTION

ENTRAPMENT PROTECTION WIRING OPTIONS

ALTERNATE INSTALLATIONS:

CPS-U PHOTOELECTRIC SENSOR WITH 2-WIRE SENSING EDGE

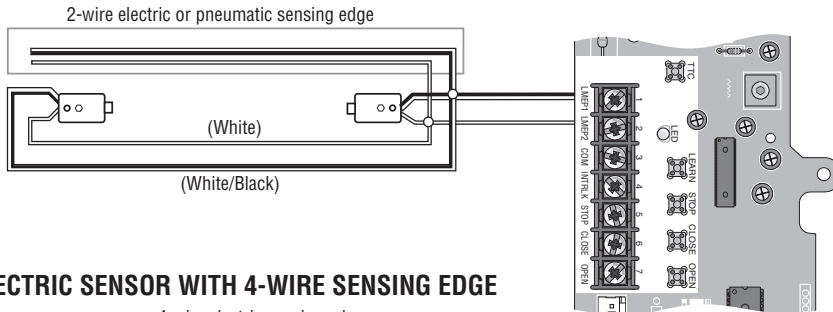

CPS-U PHOTOELECTRIC SENSOR WITH 4-WIRE SENSING EDGE

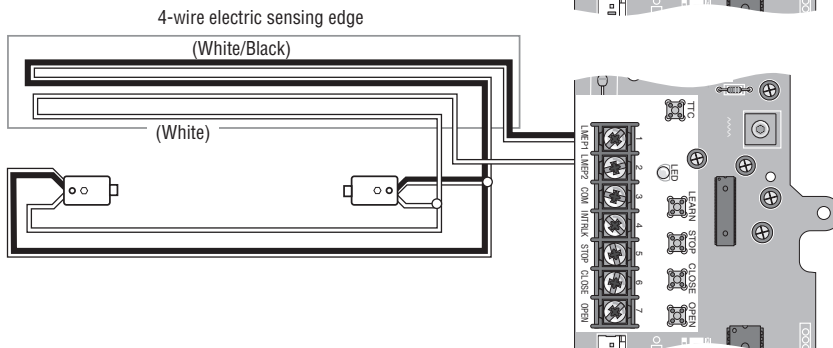

2-WIRE ELECTRIC OR PNEUMATIC SENSING EDGE (B2 NOT AVAILABLE)

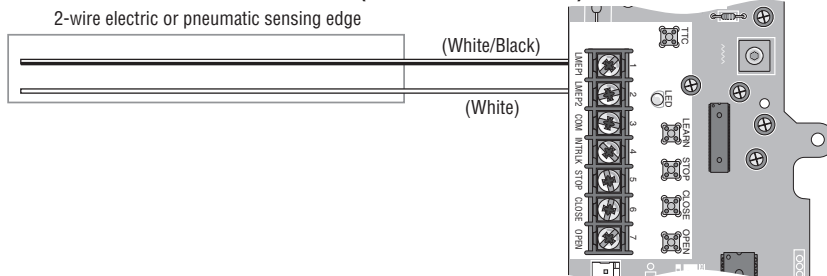

LOGIC BOARD LAYOUT

ITEM	DESCRIPTION	FUNCTION
1	Open Button	Open Door
2	Close Button	Close Door
3	Stop Button	Stop Door
4	Learn Button	Programs the remote controls and performs additional programming
5	Timer-to-Close Button	Programs the Timer-to-Close
6	Purple Wire Antenna	Primary Antenna
7	Auxiliary Antenna Connection	For use with external antenna kit -EXT-ANT. Not Provided
8	LED	Used during programming and diagnosing error codes
9	Field Wiring Terminal	Field wiring connections
10	Factory Wiring Connector	Factory wiring harness connection

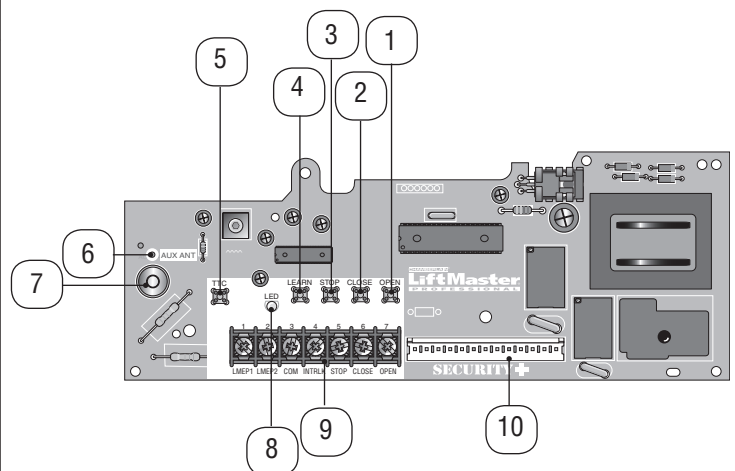

BASIC PROGRAMMING

DETERMINE THE WIRING TYPE

The functionality of this operator is based on the wiring type. The operator is shipped from the factory in standard C2 wiring type (factory default). LIFTMASTER MONITORED ENTRAPMENT PROTECTION (LMEP) DEVICE IS RECOMMENDED.

A LiftMaster Entrapment Protection (LMEP) device is **required** for any momentary contact to close mode of operation including B2, TTC and remote controls.

NOTES:

- The LED on the logic board will blink once when in C2 and twice when in B2.
 - The operator will automatically convert to B2 wiring when Monitored Entrapment Protection Device is installed. If the Monitored Entrapment Protection Device is blocked or removed, the operator will go into a Restricted Close mode**.
- ** Restricted close mode requires a constant pressure close command. The operator will begin closing after a 5 second delay and will continue to close to the close limit switch. The operator will stop if the pressure to close is released before reaching the close limit.

RECOMMENDED INSTALLATION: B2 WIRING TYPE WITH MONITORED ENTRAPMENT PROTECTION DEVICE

- Momentary contact to open, close and stop.
- Open override that reverses when closing by any opening device.
- Wiring for entrapment protection device to reverse.
NOTE: The operator will automatically convert to B2 wiring when Monitored Entrapment Protection Device is installed.
(See accessories page for Monitored Entrapment Protection Devices.)
- Timer-to-Close (TTC) feature available.

No Programming Required

MONITORED ENTRAPMENT PROTECTION DEVICE

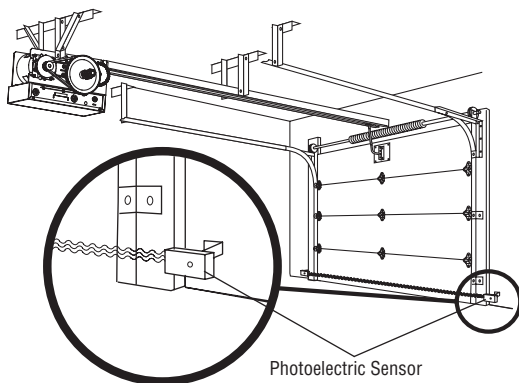

BASIC PROGRAMMING

DETERMINE THE WIRING TYPE

ALTERNATE INSTALLATION: C2 WIRING TYPE WITH MONITORED ENTRAPMENT PROTECTION DEVICE

- Momentary contact to open and stop with constant pressure to close.
- Open override that reverses when closing by any opening device.
- Wiring for entrapment protection device to reverse.
NOTE: The operator will automatically convert to B2 wiring when Monitored Entrapment Protection Device is installed. (See accessories page for Monitored Entrapment Protection Devices.)
- Timer-to-Close (TTC) feature not available.

MONITORED ENTRAPMENT PROTECTION DEVICE

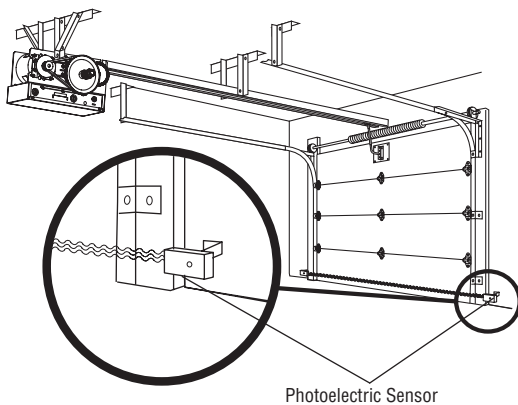

Photoelectric Sensor

To Program:

- 1 Press and hold the LEARN and CLOSE buttons until the LED goes out (approximately 3 seconds).

Electrical Box Logic Board

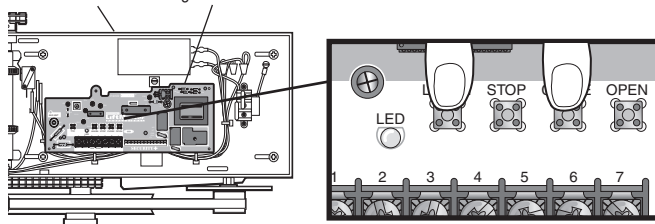

To Reset to B2 with Monitored Entrapment Protection Device:

- 1 Press and hold the LEARN and STOP buttons until the LED goes out (approximately 3 seconds).

ALTERNATE INSTALLATION: C2 WIRING TYPE WITHOUT MONITORED ENTRAPMENT PROTECTION DEVICE (FACTORY DEFAULT)

- Momentary contact to open and stop with constant pressure to close.
- Open override that reverses when closing by any opening device.
- Wiring for entrapment protection device to reverse.
NOTE: The operator will automatically convert to B2 wiring when Monitored Entrapment Protection Device is installed. (See accessories page for Monitored Entrapment Protection Devices.)
- Timer-to-Close (TTC) feature not available.

NON-MONITORED ENTRAPMENT PROTECTION DEVICE

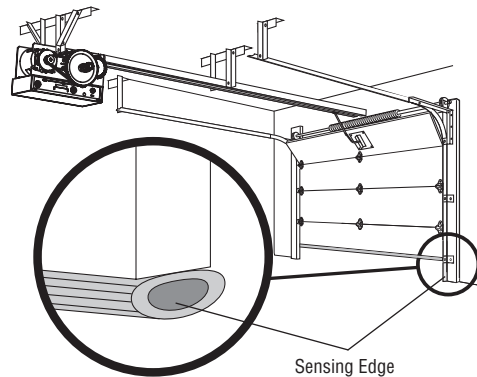

Sensing Edge

Reset to FACTORY DEFAULT (C2) when the Monitored Entrapment Protection Device has been learned and then removed:

- 1 Remove any monitored entrapment protection devices.
- 2 Turn the main power OFF and then ON to restore the operator to the FACTORY DEFAULT setting.

REMOTE CONTROLS

RADIO OPERATION

MODE	OPEN	CLOSE	STOP	REVERSE WHILE CLOSING	TTC RESET
B2	X	X	X	X	
B2 with TTC	X	X (3-button remote)	X	X	X when open
C2	X		X	X	

BASIC PROGRAMMING

REMOTE CONTROLS

⚠ WARNING

To prevent possible SEVERE INJURY or DEATH:

- Install a LiftMaster Monitored Entrapment Protection (LMEP) device.
- NEVER permit children to operate or play with door control push buttons or remote controls.
- Activate door ONLY when it can be seen clearly, is properly adjusted and there are no obstructions to door travel.
- ALWAYS keep door in sight until completely closed. NEVER permit anyone to cross the path of closing door.

Built in 315 MHz radio receiver permits as many as 20 Security+® remote controls or dip switch remote controls in any combination.

SINGLE BUTTON REMOTE CONTROL

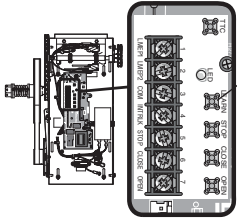
1  Press and release the LEARN button (LED will light).

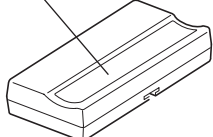
2  Press and hold the button on the remote control until the LED flashes rapidly, then release to complete programming (LED will go out).

Repeat steps 1 and 2 for additional remote controls.

TO ERASE ALL REMOTE CONTROLS

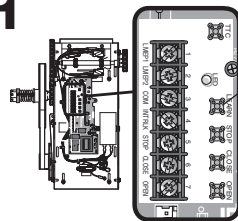
1  Press and hold the LEARN button (over 5 seconds) until the LED goes out. All programmed remote controls will be erased.

3-BUTTON REMOTE CONTROL TO OPERATE AS A WIRELESS 3-BUTTON CONTROL STATION

NOTE: The feature will use 3 of the 20 memory channels in the operator.

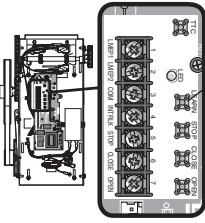
1  Press and hold the LEARN button (LED will light).

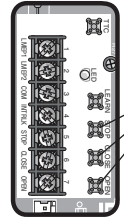
2  Press the desired button on the logic board (OPEN, CLOSE or STOP). Release both buttons.

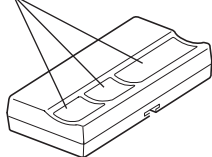
3  Press and hold the desired button of the remote control until LED flashes rapidly, then release.

Repeat steps 1 through 3 to program additional buttons.

TIMER-TO-CLOSE (TTC)

Timer-to-Close feature enables the operator to close from the open limit after a preset time, adjustable from 5 to 60 seconds. **Requires LiftMaster Monitored Entrapment Protection (LMEP) device.** **NOTE:** The TTC will attempt to close the door 5 consecutive times. If the door fails to close, (sensors obstructed, OPEN command given, etc.) the TTC is canceled for that cycle and a manual CLOSE command will be required. The TTC will automatically reactivate on the next cycle.

TO PROGRAM

Begin with door in fully closed position.

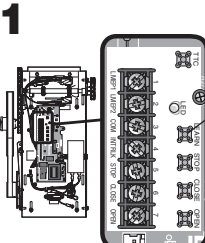
1  Press and release the LEARN button (LED will light).

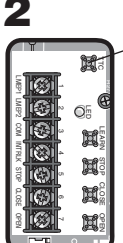
2  Press and release the TTC button.

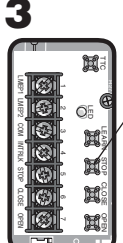
3  Every press and release of the STOP button will add 5 seconds to the Timer-to-Close. Example: 30 second TTC = 6 presses of the STOP button.

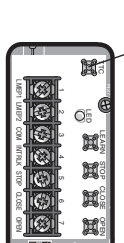
4  Press and release the TTC button to exit programming mode. The LED will flash once per 5 seconds of timer setting.

The TTC will become active after completion of the next open cycle. **NOTE:** The LED does not indicate that timer is running.

TO VERIFY TIMER-TO-CLOSE (TTC) SETTING

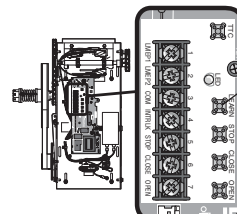
1  Press and hold the LEARN button (LED will light).

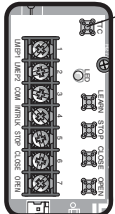
2  Press and release the TTC button.

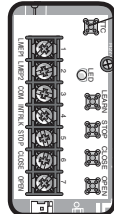
3  Press and release the TTC button a second time. The LED will flash once per 5 seconds of timer setting.

BASIC PROGRAMMING

TIMER-TO-CLOSE (TTC)

CLEAR THE TIMER-TO-CLOSE (TTC)

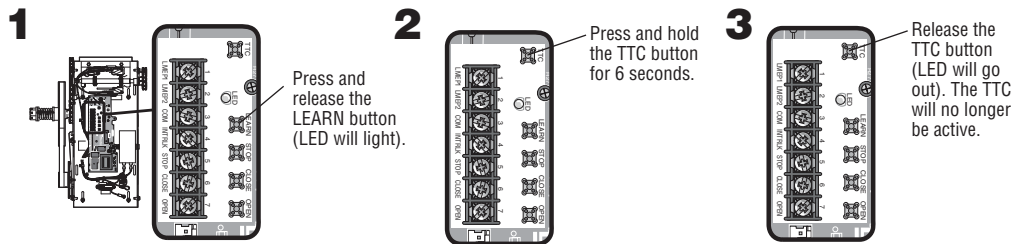

TIMER DEFEAT

The TTC can be temporarily disabled by pressing a STOP button.

TTC will become enabled after the next open command.

TESTING

WARNING

To avoid SERIOUS personal INJURY or DEATH:

- Disconnect electric power BEFORE performing ANY adjustments or maintenance.
- ALL maintenance MUST be performed by a trained door systems technician.

Turn on power, LED will flash 4 times on power up. Test all controls and entrapment protection devices to make sure they are working properly. It may be necessary to refer back to the Adjustment section for adjustment of the limits.

IMPORTANT NOTES:

- Do not leave power to the operator on unless all entrapment protection devices have been tested and are working properly.
- Be sure you have read and understand all safety instructions included in this manual.
- Be sure the owner or person(s) responsible for operation of the door have read and understand the safety instructions, know how to electrically operate the door in a safe manner and how to manually disconnect the door from the operator.

TEST 3-BUTTON CONTROL STATION

- 1** Press OPEN button. (The door should move in the open direction.)
- 2** Press STOP button. (The door should stop.)
- 3** Press CLOSE button. (The door should move in the close direction.)
- 4** Release CLOSE button. Door should stop if in C2 mode. (The door should continue closing if in B2 mode.)
- 5** Press STOP button. (The door should stop.)

TEST LIMIT ADJUSTMENT

- 1** Press OPEN button. (The door should open.)
- 2** Allow the door to fully open.
- 3** Press CLOSE button. (The door should close.)
- 4** Allow the door to fully close.

If the limits are not set properly, remove power and adjust limits (refer to Adjustment section).

TEST THE ENTRAPMENT PROTECTION DEVICES

- 1** Open the door.
- 2** Place an obstruction in the path of the photoelectric sensors or sensing edge.
- 3** Press the CLOSE button. The door should not close if photoelectric sensors are installed. The door should close to obstruction and reverse if sensing edge is installed.
- 4** Remove the obstruction.
- 5** Press CLOSE button. Door should close.

If door did not reverse from obstruction, check entrapment protection devices.

TEST REMOTE CONTROL

Requires B2 wiring type and compatible LiftMaster remote control. In C2 wiring the remote control will open the door only.

- 1** Press remote control button.
- 2** Door should open. Allow the door to fully open.
- 3** Press remote control button.
- 4** Door should close. Allow door to fully close.

EMERGENCY DISCONNECT

⚠ WARNING

To prevent possible **SERIOUS INJURY** or **DEATH** from a falling door or arm:

- **DO NOT** stand under the door arm when pulling the emergency release.
- If possible, use emergency release handle to disengage trolley **ONLY** when door is **CLOSED**. Weak or broken springs or unbalanced door could result in an open door falling rapidly and/or unexpectedly.
- **NEVER** use emergency release handle unless doorway is clear of persons and obstructions.
- If door locks have been installed, disengage door locks prior to releasing the emergency release handle.

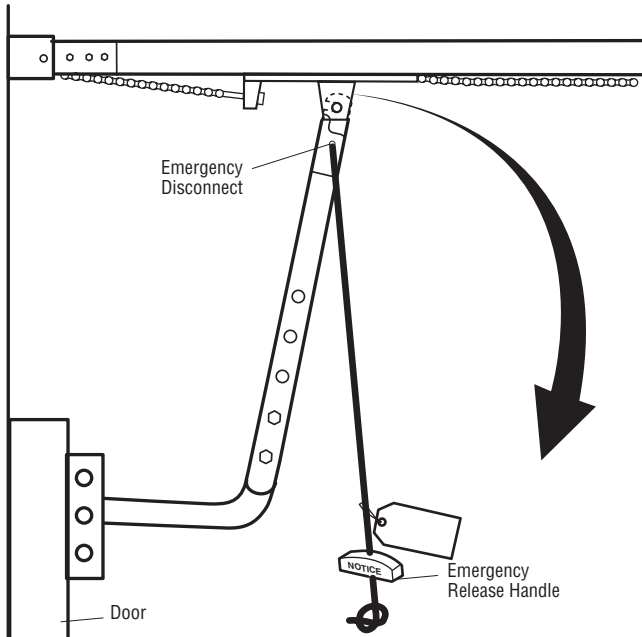

TO DISCONNECT DOOR FROM OPERATOR

- 1** Pull emergency release handle straight down. Emergency disconnect will open.

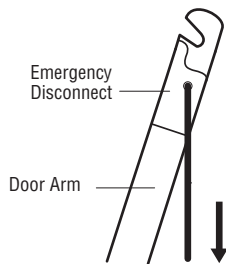

TO RECONNECT DOOR ARM TO TROLLEY

- 1** Lift free end of door arm to trolley.
- 2** Pull emergency release handle to allow arm to engage roll pin.
- 3** Let go of the emergency release handle. Emergency disconnect will close.

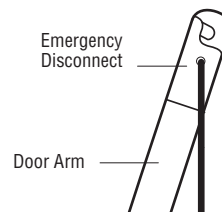

TROUBLESHOOTING

Technical Support 1-800-528-2806

CONDITION	POSSIBLE CAUSE	FIX
OPERATOR WILL NOT RESPOND TO ANY COMMANDS	A) No power	➤ Verify primary line voltage (120 Vac, 60 Hz) is present at terminals L1 & L2. The LED will flash when power is present.
	B) Stop circuit not complete	➤ Verify Stop Button input (terminals 3 & 5) is properly wired and stop button is not stuck.
	C) Stuck button on 3-button control station	➤ Verify that all buttons are actuating freely and releasing properly.
	D) Interlock input activated	➤ Verify jumper is located at terminals 3 & 4 if interlock is not present. ➤ Verify interlock is properly wired and not activated.
	E) Motor overload tripped	➤ Overload is internal within motor. Allow to cool and retry.
	F) Accessory failure	➤ Attempt to close by holding the CLOSE button for more than 5 seconds. If door closes, check accessory for proper wiring, polarity, connections or damage. ➤ Verify photoelectric sensors are aligned or sensing edge is not activated.
	G) Possible component failure	➤ Call Technical Support for assistance.
OPERATOR MAKES NOISE BUT DOOR DOES NOT MOVE	A) Clutch slipping	➤ Adjust clutch, see ADJUSTMENT section.
	B) Brake not releasing (if present)	➤ Verify brake assembly operation and wiring.
	C) Door operation problem	➤ Disconnect trolley and check door for proper operation.
OPERATOR MOVES IN THE WRONG DIRECTION	OPEN and CLOSE button wiring connection reversed	➤ Check 3-button control wiring.
DOOR DRIFTS AFTER OPERATOR STOPS	A) Door not balanced properly	➤ Disconnect trolley assembly and check door for proper operation.
	B) Clutch slipping	➤ Adjust clutch, see ADJUSTMENT section.
	C) Brake not functioning properly	➤ Check brake mechanism to ensure brake lever is free and brake pads are engaging the brake disc.
DOOR OPENS/CLOSES TOO FAR	Limits not adjusted properly	➤ Adjust limits. See ADJUSTMENT section.
DOOR REVERSES UNEXPECTEDLY	Intermittent Entrapment Protection Device activation	➤ Check all connections.
TTC NOT FUNCTIONING	A) Monitored Entrapment Protection Devices	➤ Check all connections. Verify photoelectric sensors are not blocked and the sensing edge is not activated.
	B) TTC temporarily disabled	➤ Close and Open the door. TTC will be re-enabled.
	C) TTC not programmed properly	➤ Reprogram TTC. See PROGRAMMING TTC section.
RADIO FUNCTIONALITY	<i>NOTE: Built in radio receiver compatible with all LiftMaster 315 MHz remote control devices.</i>	
NO RESPONSE	A) Remote control is not programmed	➤ See PROGRAMMING REMOTE CONTROLS section.
	B) Remote control not compatible	➤ Obtain qualified LiftMaster remote control device.
	C) Low battery	➤ Replace battery.
REMOTE CANNOT BE LEARNED	A) Low battery	➤ Replace battery.
	B) Remote control not compatible	➤ Obtain qualified LiftMaster remote control device.
POOR RADIO RANGE	A) Low battery in remote	➤ Replace battery.
	B) Antenna not configured	➤ See SETUP RADIO ANTENNA.
	C) Ambient radio interference or building structural issue	➤ Use EXTERNAL ANTENNA kit (see ACCESSORIES page).

TROUBLESHOOTING

The status of the operator can be determined by counting the number of flashes of the LED on the logic board.

DIAGNOSTIC LED TABLE		
# OF LED FLASHES	STATUS	FIX
1	System OK. Operating in C2 mode	None
2	System OK. Operating in B2 mode	None
3	Stuck CLOSE button	Check for stuck close button or shorted close wire
4	Monitored Entrapment Protection Device failure	Check for: 1) Misaligned or blocked Photoelectric Sensors. 2) Issue with Monitored Sensing Edge and/or wiring.
5	Incorrect motor direction	Reverse the yellow and red motor wires on the capacitor.
6	Maximum run timer has timed out (Maximum run time = 90 seconds)	Check clutch adjustment. Door height or speed may exceed the range the operator can travel. Call Technical Support for assistance.
7	Logic Board Failure	Replace Logic Board. NOTE: It is normal for the logic board LED to flash 4 times when power is applied or cycled to the operator. (Not a logic board failure.)

RESTRICTED CLOSE

This method will allow you to close the door when LMEP device(s) are no longer working. Press and hold the CLOSE button until the door reaches the closed limit. If the CLOSE button is released before the door reaches the closed limit the operator will stop and the procedure will need to be repeated to fully close the door.

DIAGRAM

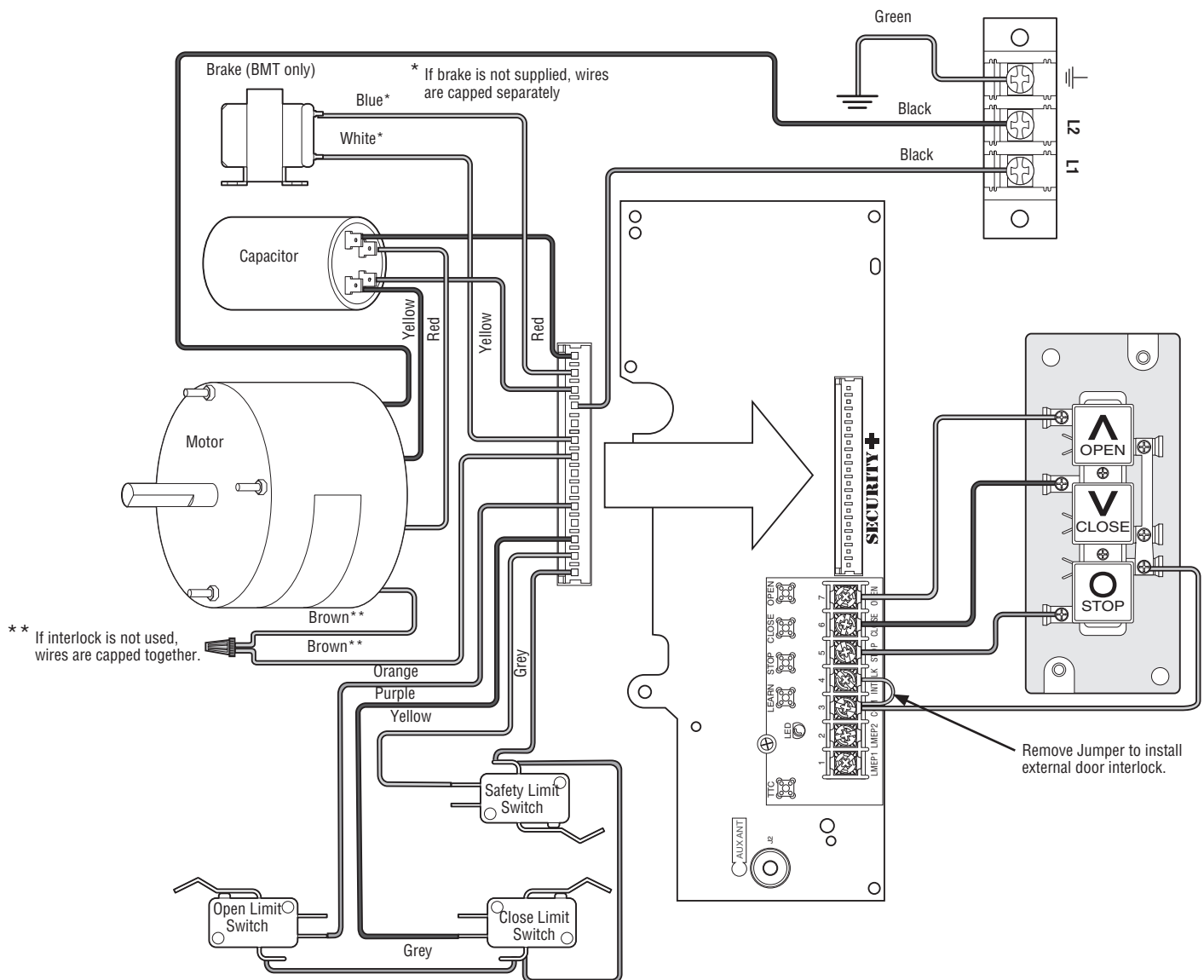

ACCESSORIES

ENTRAPMENT PROTECTION DEVICES

MONITORED

CPS-U



Dual-Sided Infrared Photo Eyes

- NEMA 1 general purpose enclosure.
- Dual-sided infrared sensors.
- For indoor use.
- Maximum range of 30 feet (9.1 m).

CPS-UN4



Monitored Thru-Beam Photo Eyes

- Heavy-duty housing for industrial applications.
- NEMA 4 enclosure protects against direct spray.
- Dual-sided infrared sensors.
- For indoor/outdoor use.
- Maximum range of 45 feet (13.7 m).

CPS-RPEN4



Monitored Retro-Reflective Photo Eyes

- Polarized reflector for use in applications with highly reflective surfaces.
- NEMA 4X enclosure protects against direct water spray and corrosion.
- Retro-reflective sensor.
- For indoor/outdoor use.
- Maximum range of 50 feet (15 m).

CPS-OPEN4



Monitored Dual-Sided Photo Eyes

- Flexible housings maintain alignment in areas with a high propensity for sensor contact.
- NEMA 4X enclosure protects against direct water spray and corrosion.
- Dual-sided infrared sensors.
- For indoor/outdoor use.
- Maximum range of 45 feet (13.7 m).

Optical Edge System (OES)

OES-SD16

Optical Edge System

16 feet (4.9 m) Sectional 2-Wire Door Edge Kit with infrared optical sensors, rubber door edge and all mounting hardware (channel sold separately).



OES-SD24 Optical Edge System

24 feet (7.3 m) Sectional 2-Wire Door Edge Kit with infrared optical sensors, rubber door edge and all mounting hardware (channel sold separately).



OES-RD16 Optical Edge System

16 feet (4.9 m) Rolling 2-Wire Door Edge Kit with infrared optical sensors, rubber door edge and all mounting hardware (door channel not required).



- Rubber door edge is durable, flexible and easy to install.

- Premium rubber can be cut to length for exact fit.
- NEMA 6 rating protects against moisture and standing water.
- Infrared optical sensors eliminate the need for electrical contacts.
- Maximum range of 33 feet (10 m).
- Sectional and rolling door edges are also available in 50 foot (15 m) bulk rolls, along with individual components for additional savings on large installation jobs.

CPS-EI

Edge Interface 4-Wire Monitored

For use with approved 4-wire edges.

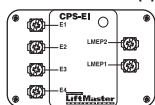

REMOTE CONTROLS 315 MHZ



LiftMaster offers a variety of **SECURITY+®** Remote Controls for your application needs. Single to 4-Button, visor or key chain. Contact your authorized dealer.

371LM

1-Button SECURITY+® Remote Control

Includes visor clip.

373LM

3-Button SECURITY+® Remote Control

Includes visor clip.

333LM

3-Button Tri-Colored Dip Switch Remote Control

Open/Close/Stop functionality. Includes visor clip.

CONTROL STATIONS

02-102



2-Button Control Station

Steel enclosure.

02-103



3-Button Control Station

Steel enclosure.

02-109



Key Control Station

Indoor flush mount, NEMA 1.

DOOR INTERLOCK SWITCH

50 401

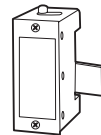

Rolling Door Interlock Switch: NEMA 1 switch is engaged by rolling door lock mechanism and disables operator control circuit when door is locked, thereby preventing electrical operation of door when locked. Mounts at bottom of door guide, requires 2-wire connection to operator. May be used with all LiftMaster industrial operators on rolling doors.

50 450



Sectional Door Interlock Switch: NEMA 4 switch is engaged by sectional door lock mechanism and disables operator control circuit when door is locked, thereby preventing electrical operation of door when locked. Mounts next to door lock, requires 2-wire connection to operator. May be used with all LiftMaster industrial operators on sectional doors.

FIELD MODIFICATION KITS

71MLSBC

Single Button Control: Provides additional input for Single Button Control functionality. Input functions as Close input when the operator is stopped at the Open limit. Input functions as Open input at all other times. Also used with external radio controls.

71 MLMOTION

Door-In-Motion: Provides dry contact and a terminal block with contacts switched to power an auxiliary device while the door is in motion.

ANTENNA

EXT-ANT



Antenna: External kit for medium duty.

86LM (15' [4.6m])

Antenna Extension Kit: The antenna extension

86LMT (25' [7.6 m])

kit can be used with EXT-ANT for maximum radio receiver range.



CONTROL CONNECTION DIAGRAM

IMPORTANT NOTES:

1. The 3-Button Control Station provided must be connected for operation.
2. If a STOP button is not used, a jumper must be placed between terminals 3 and 5.
3. If INTERLOCK is not used a jumper must be placed between terminals 3 and 4.
4. When adding accessories, install them one at a time and test each one after it is added to ensure proper installation and operation with the Commercial Door Operator.

